

Refinish sanding at its best

 **TESLA CURE**
RAPID REPAIR SOLUTIONS

 **100% GERMAN
TECHNOLOGY**



**TESLA CURE RANDOM
ORBITAL SANDER**

Refinish sanding at its best



- **Long lifetime powerful 400 watt brushless motor**
- **Light Weight, easy to use on horizontal and vertical areas**
- **Fully wrapped in a soft textured rubber finish for comfort**
- **Increased airways for high performance dust extraction**
- **Built-in LED light to see fine imperfections when sanding**
- **Extremely smooth action with little or no vibration**
- **Fault protection electronics to ensure long life**
- **Built in cooling system to ensure the machine runs cool**
- **Adjustable speed from 4,000 to 10,000 RPM**
- **Available in 5mm orbit and 3mm orbit**
- **Tested against FESTOOL ETS EC 150/5 EQ-Plus**
- **Tested against MIRKA DEROS 650 CV EU**



Refinish sanding at its best



In-Built LED Light

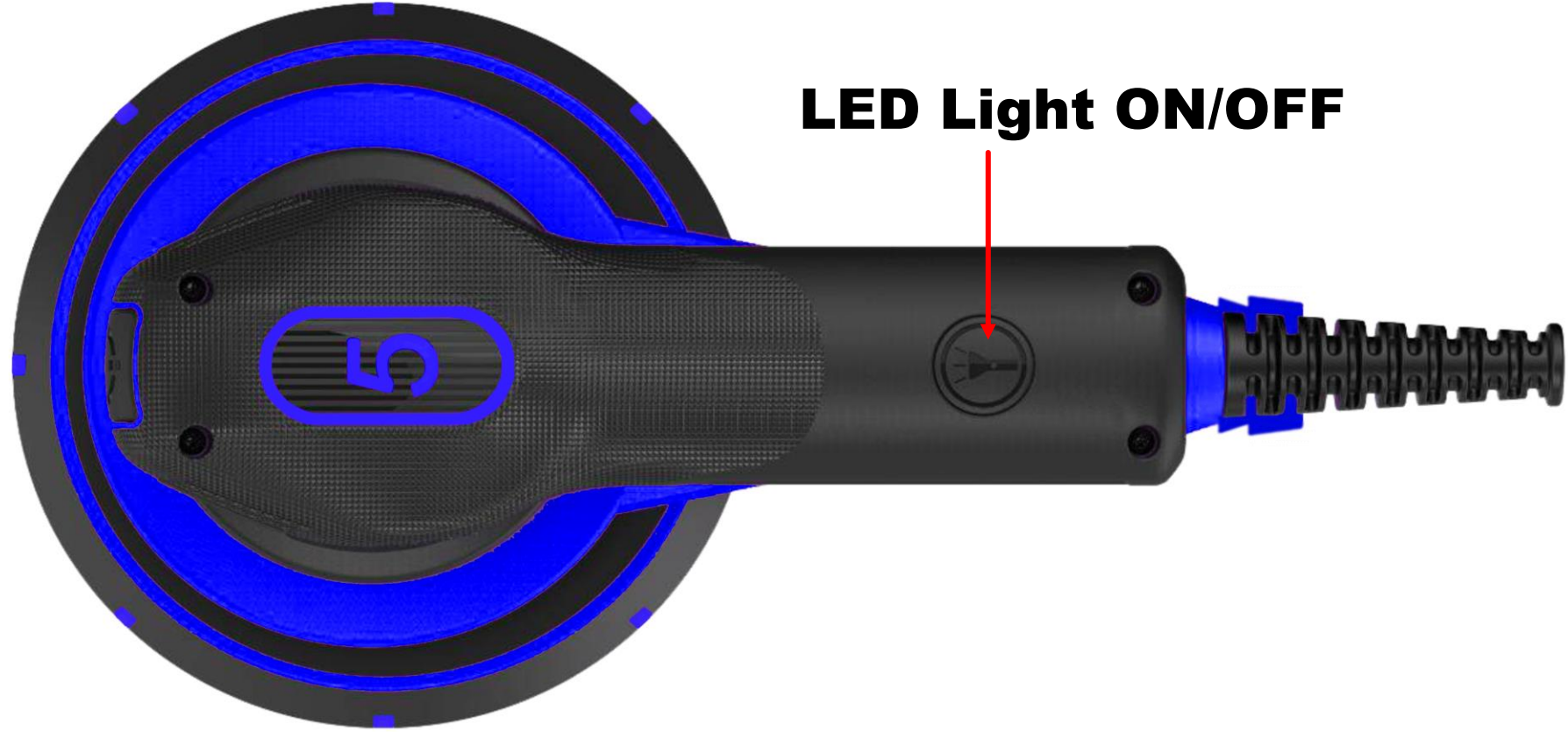
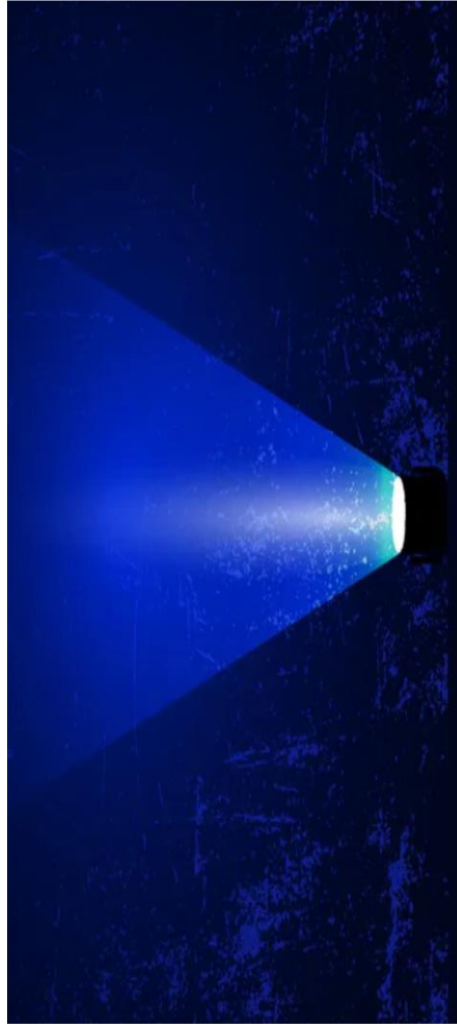

LED Light ON/OFF

Refinish sanding at its best

Large easy to reach
ON/OFF switch

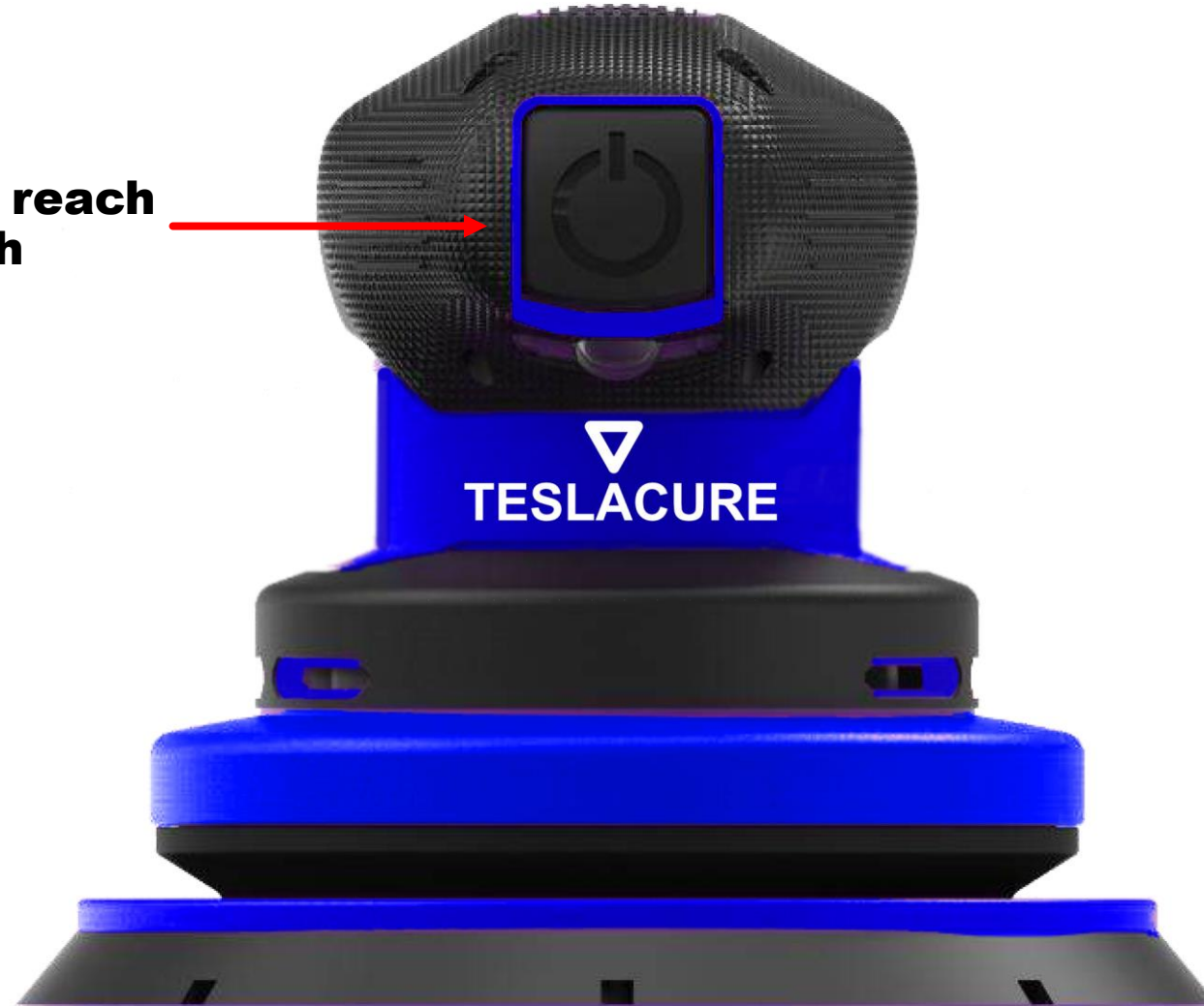

Performance at its best



**Roller speed control wheel to adjust
from 4,000 to 10,000 RPM**

Performance at its best

The bearings, eccentric block, air blade turbine and sanding pad have been precisely balanced to achieve a smooth vibration free sanding experience.

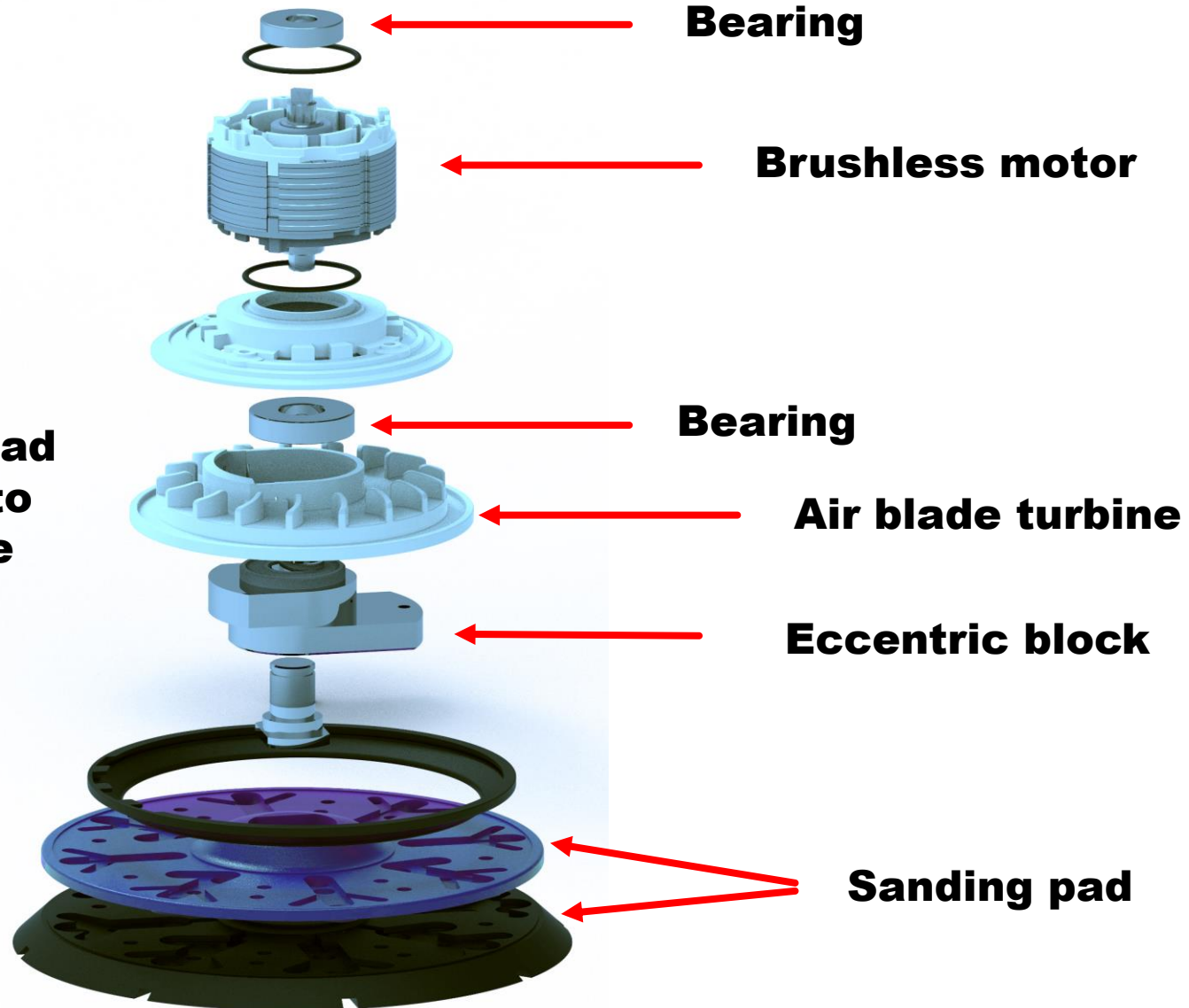

Quality & Reliability at its best

Powerful brushless motor

**New generation high performance,
low vibration motor with high-torque**

**The brushless motor has been tested
for long life and performance with over
3,000 hours on test with no failures**

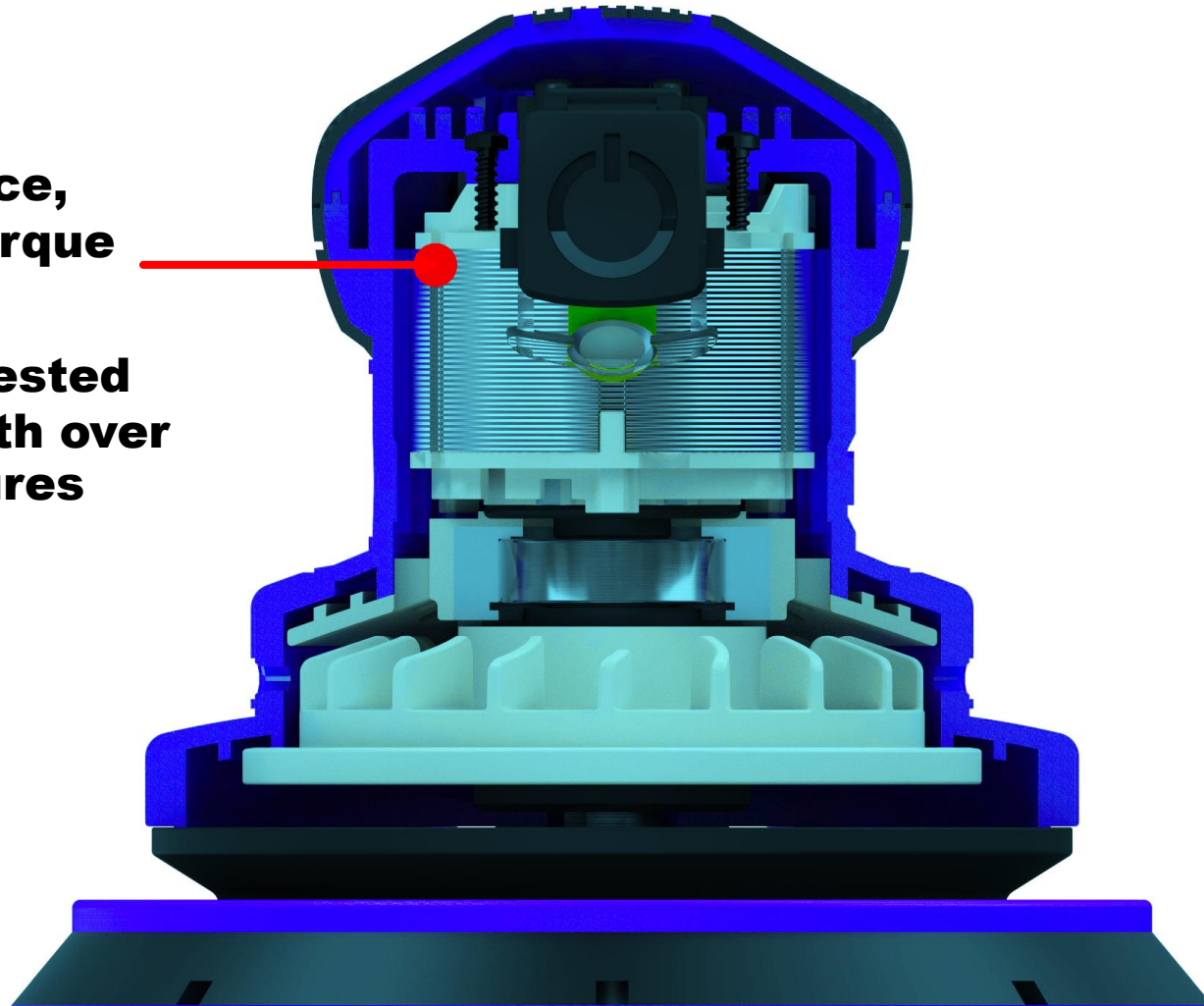

Quality & Reliability at its best



Designed with the latest internal dust protection

Switch dust seal

Motor fully sealed

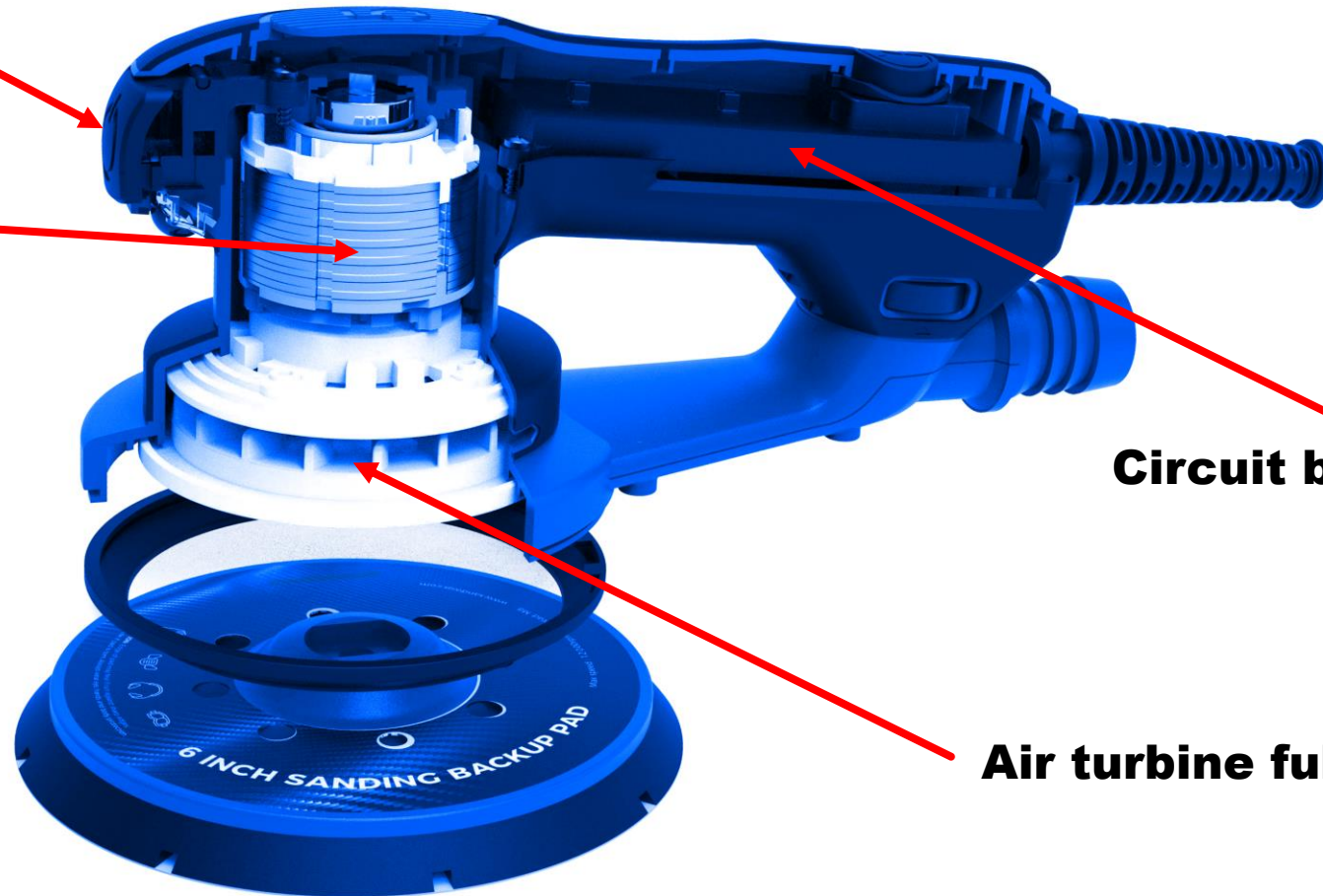

Circuit board fully sealed

Air turbine fully sealed

Quality & Reliability at its best

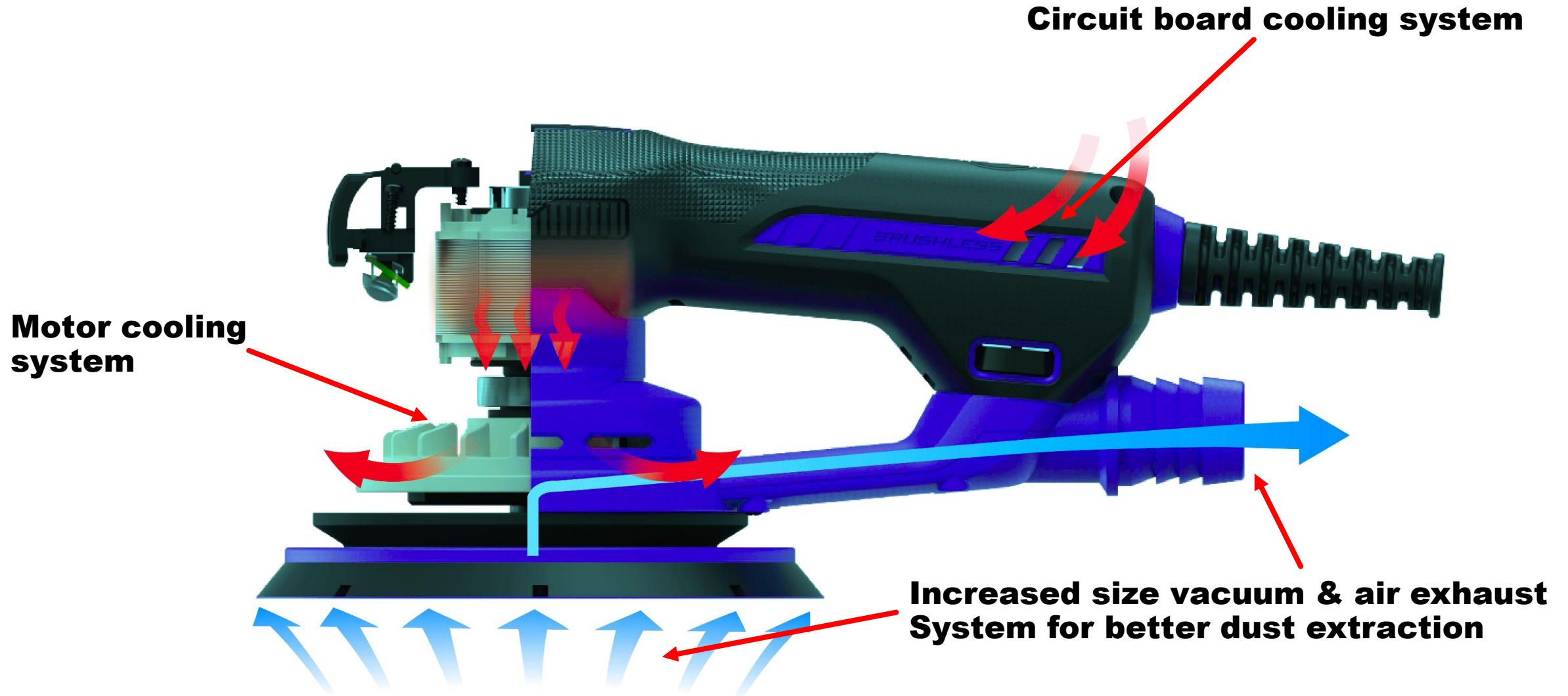

Quality & Reliability at its best

**Increased size vacuum airways
designed into the backup pads to
allow for high performance exhaust
and better dust extraction**

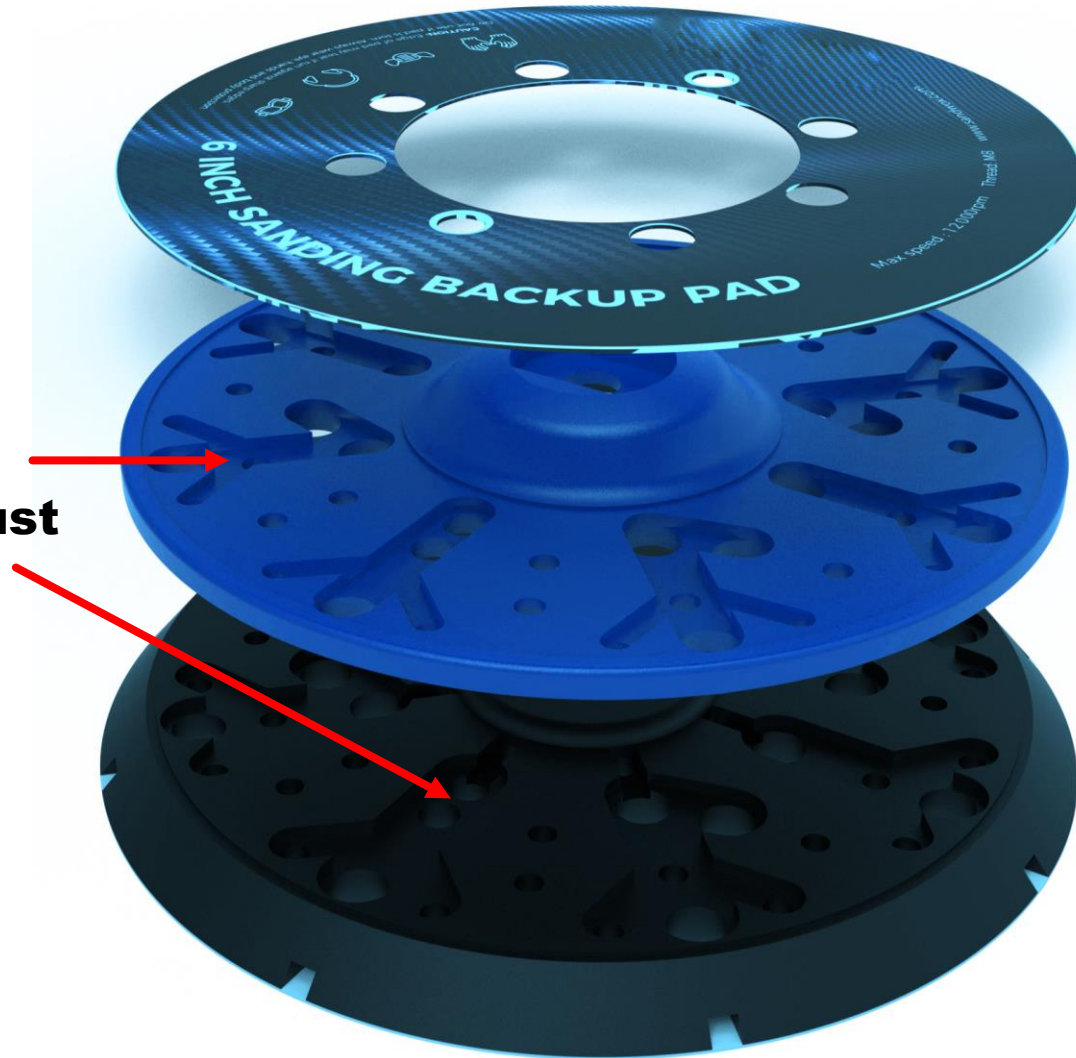

Quality & Reliability at its best

Special Designed Circuit Board

Intelligent protection system, triple protection of short circuit, over temperature and over current, stable and reliable

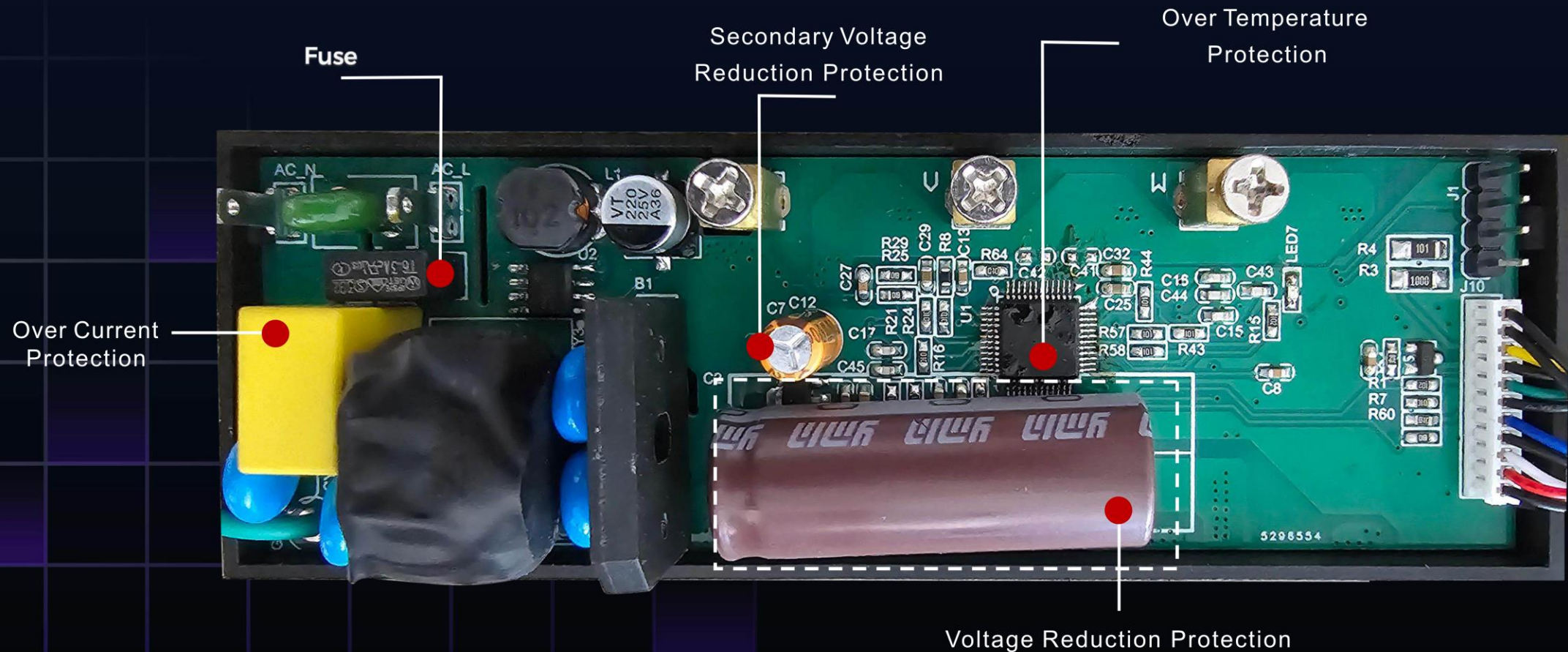

SKORPIO E

Power	250W
No-load speed	4000-10000RPM
Eccentricity	6/3 (m m)
Sanding pad size	150 (m m)
Need to keep switch switch pressed to operate	YES
Noise	81 dB
weight	1.2 (kg)

RUPES®

COMPARISONS



DEROS 650CV EU

Power	350W
No-load speed	4000-10000 RPM
Eccentricity	5/3 (m m)
Sanding pad size	150 (m m)
Need to keep switch switch pressed to operate	YES
Noise	83 dB
weight	1.1 (kg)

MIRKA

COMPARISONS



ETSEC 150/5 EQ-Plus

Power	400W
No-load speed	4000-10000 RPM
Eccentricity	5/3 (m m)
Sanding pad size	150 (m m)
Need to keep switch switch pressed to operate	NO
Noise	81 dB
weight	1.5 (kg)

FESTOOL

COMPARISONS



TESLACURE TC-150-5

Power	400W
No-load speed	4000-10000RPM
Eccentricity	5/3 (m m)
Sanding pad size	150/125 (m m)
Need to keep switch switch pressed to operate	NO
Noise	78 dB
weight	1.3 (kg)

TESLACURE ▽



Premium Packaging



Fantastic Price